



**SUMMARY:**

The purpose of this document is to present a solution to the anode rod quality issue discussed in technical service bulletins released by Dectra Corporation on 10/24/2015 and 11/16/2015.

Part 1: 10/24/2015	Discusses the awareness of the anode rod quality issue.
Part 2: 11/16/2015	Discusses research into the issue and background information.
Part 3: (this part)	Discusses the proposed solution of electric isolation OR single-point grounding.

Electric isolation will now be the standard installation method for all GARN® units to combat complications from undirected current. Electric isolation is an equivalent substitute for the installation of consumable anode rods and accomplishes the same level of protection. For existing customers, electrical isolation is an easy retrofit that needs to be completed. The following is discussed:

**TABLE OF CONTENTS**

SUMMARY:..... 1  
WHY ARE ANODE RODS IN GARN® UNITS? ..... 1  
UNDIRECTED CURRENT - TERMINOLOGY:..... 1  
CORROSION FROM UNDIRECTED CURRENT:..... 1  
PROTECTING AGAINST UNDIRECTED CURRENT: ..... 1  
SOLUTION (REQUIRED ACTION): ..... 2  
    For EXISTING CUSTOMERS:..... 2  
    For NEW CUSTOMERS:..... 2  
ELECTRIC ISOLATION: ..... 2  
    IF ELECTRIC HEATING ELEMENTS ARE INSTALLED: ..... 2  
    LOW VOLTAGE SENSORS: ..... 2  
    UNITS WITHOUT ELECTRIC HEATING ELEMENTS:..... 3  
    UNITS WITH ELECTRIC HEATING ELEMENTS:..... 6  
CONCLUSION:..... 7  
FAQ:..... 7  
ELECTRIC ISOLATION BUSHING INSTALLATION INSTRUCTIONS: .. 8

**WHY ARE ANODE RODS IN GARN® UNITS?**

To reinforce what has been discussed in the previous two bulletins, anode rods were supplied with GARN units because they were a simple solution to deal with the possibility of undirected current corrosion. This technique is known as *passive cathodic protection*. The intent of the rods is to act as a “canary in the coal mine,” to indicate to the user that something may be amiss electrically (undirected current may be present).

For example, if, after initial filling and operation, an anode rod pitted in a quick time frame (roughly 1 to 3 months or slightly more), then there was reason to suspect an *undirected current* problem. In such cases, the anodes would have been monitored

carefully and replaced as necessary to prevent tank damage until the electrical problem was corrected.

But, if history with a specific unit had shown that anode rods lasted on the order of years, then there was likely no undirected current problem. In this case, the anode rods can be permanently removed without risking harm to the thermal storage tank.

**UNDIRECTED CURRENT - TERMINOLOGY:**

The terms *stray voltage*, *electrolysis*, and *undirected current* all describe the same concept in the context of a GARN unit. The term *undirected current* will be used throughout this paper because we believe it is the most accurate term. Undirected current is electric current that inappropriately “leaks” through the GARN unit to an electrical ground.

**CORROSION FROM UNDIRECTED CURRENT:**

All corrosion occurs by an oxidation process. An oxidation process involves the movement of electrons between elements. Electric current is a measurement of the amount of moving electrons. Therefore, corrosion and electric current are fundamentally linked together.

Undirected current can amplify corrosive effects of galvanic corrosion or it can, by itself, generate corrosive effects, both of which can affect a GARN unit. In almost all cases, if undirected current affects an installation, diagnosis and troubleshooting by a qualified electrician is generally required to find the root cause and correct it.

**PROTECTING AGAINST UNDIRECTED CURRENT:**

There are several ways to protect equipment from undirected current, but the most common are:

1. Passive cathodic protection (Mg, Al, or Zn anode)
2. Active cathodic protection (uses a titanium filament and power supply to drive a DC current to offset any undirected current that may be present)
3. Electric isolation and Specific Grounding Procedures

For years, GARN units have successfully used passive cathodic protection with a magnesium anode rod and independent grounding rod. But, passive cathodic protection is no longer an option because suppliers cannot guarantee that the rods will meet specification for use in GARN equipment. Active cathodic protection is prohibitively expensive (an estimated retail cost of \$2500 for a WHS-2000). For these reasons, we are now recommending that all customers take steps to electrically isolate their units and follow specific grounding procedures. Anode rods will no longer be sold as replacement parts or provided with the purchase of a new GARN unit.



**SOLUTION (REQUIRED ACTION):**

There are two options available to accomplish undirected current protection in a GARN unit:

1. **FULL ISOLATION (RECOMMENDED):** Electrically isolate the GARN unit from any wired ground path. That means that the GARN tank will not be electrically connected to any wired device that is connected to power or to ground.

----- OR -----

2. **SINGLE POINT GROUNDING:** Have a single ground point for all wired electrical devices in electrical contact with the GARN unit.

Our recommend solution is *full electric isolation* (Option 1). But, depending on the installation, full electric isolation may be difficult or impossible to implement, so *single point grounding* (Option 2) may be the most reasonable approach.

**For EXISTING CUSTOMERS:**

- Assess the anode rods (per the previous technical service bulletins).
  - If the anode rods DO show signs of the quality issue, remove the rods, and plug the anode rod holes with a 3/4" NPT steel pipe plug using Teflon tape or pipe dope.
  - If the anode rods DO NOT show signs of the quality issue, then the rods may remain in the unit until the end of their useful life or they can be immediately removed (up to the user).
- Assess the overall condition of the GARN tank. Remove any rod debris, sludge, and/or sluff build-up on the bottom of the tank. If there is build-up that cannot be easily removed while the tank is filled (in service), now would be a good time to drain the unit, clean it, and refill it with fresh water and chemical.
- Electrically isolate the tank following the steps outlined in the following sections.

**For NEW CUSTOMERS:**

- Anode rods will no longer be supplied with a GARN unit. Electric isolation is required as part of installation. Follow the steps in the following sections.

**ELECTRIC ISOLATION:**

The following diagram shows a typical GARN installation with no electrical isolation and two separate ground paths: one through the electrical panel, and one through the independent ground rod of the GARN unit. In the following instructions, we will build off of this diagram for explanation and illustration.

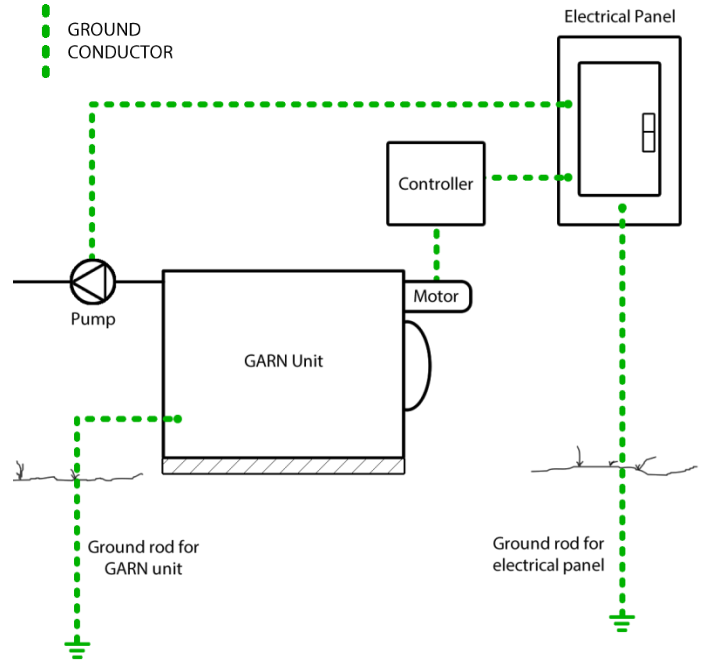

**CAUTION** All electrical work must be completed by a licensed electrician in compliance with all Federal, State, and local codes.

**IF ELECTRIC HEATING ELEMENTS ARE INSTALLED:**

**IMPORTANT** If electric heating elements are installed, skip to the section [UNITS WITH ELECTRIC HEATING ELEMENTS](#): on page 6. When electric heating elements are installed, single point grounding must be used, but specific grounding procedures must be followed.

**LOW VOLTAGE SENSORS:**

Low voltage sensors do not need isolation accommodations as these sensors are almost universally ground isolated due to their inherent signal sensitivity.



**UNITS WITHOUT ELECTRIC HEATING ELEMENTS:**

**FULL ISOLATION (OPTION 1)**

**1** Disconnect the independent ground rod:

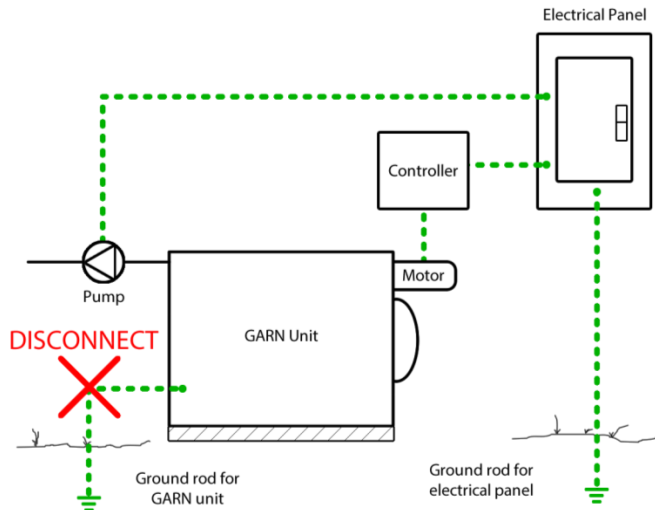

**2** Check to ensure that the unit is set on foam:

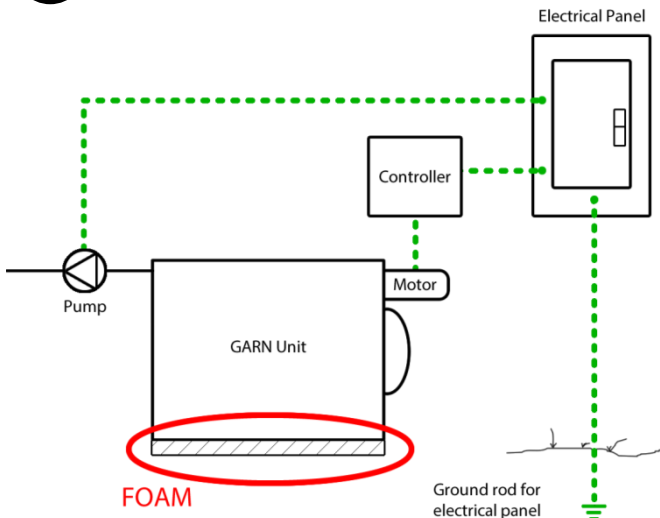

**3** Isolate the blower motor with a blower motor isolation kit: (Part #: [P-0125 on www.garnparts.com](http://www.garnparts.com)). Installation instructions for the isolation kit can be found on [PAGE 8](#).

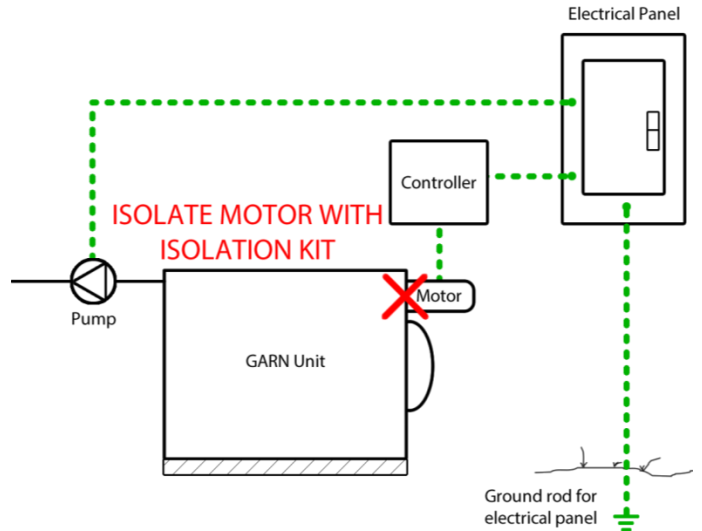

**4** Dielectrically isolate any pumps directly connected to the GARN unit:

A pump is dielectrically isolated if there is a means that breaks the metal-to-metal contact between the pump housing itself and the GARN unit. Examples of di-electric isolation include: dielectric unions, any length of PEX, or isolation valve flanges attached directly to the pump (such as [Grundfos dielectric isolation valves](#)).

The following picture shows a pump that is dielectrically isolated from the GARN unit:

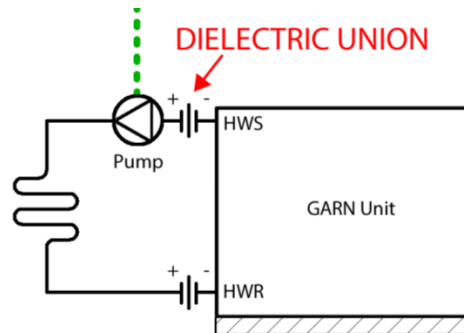

By installing dielectric unions (or equivalent) on or near the Hot Water Supply (HWS) and Hot Water Return (HWR) connections of the GARN unit, electric isolation is achieved for any and all components connected downstream.



5 Isolate the controller:

In some installations, the controller may be directly screwed into steel studs. The steel studs may then be in direct contact with the GARN unit. In such a situation, the housing of the controller is effectively a ground path to the tank.

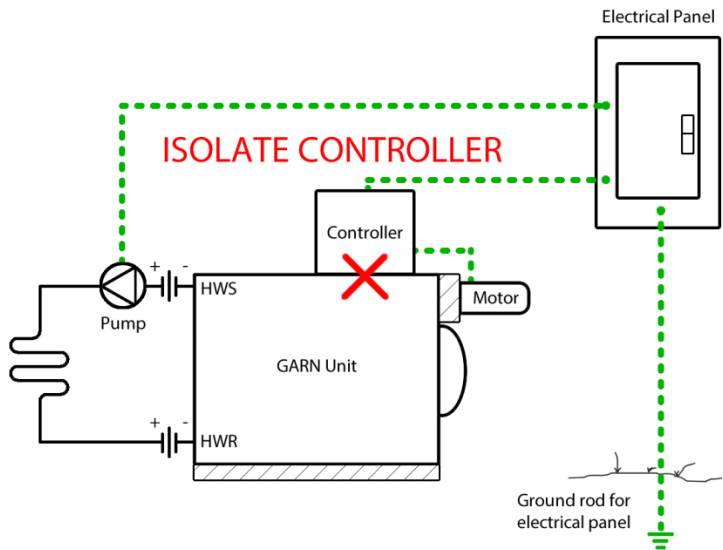

A simple solution to isolate the controller is to remove the controller from its steel stud mounting, screw a piece of plywood into the steel studs, then mount the controller to the plywood. Make sure the new controller mounting screws are not in contact with the steel studs. Plywood is an effective electric isolator.

6 Isolation is now complete, and the schematic of how the installation should look is:

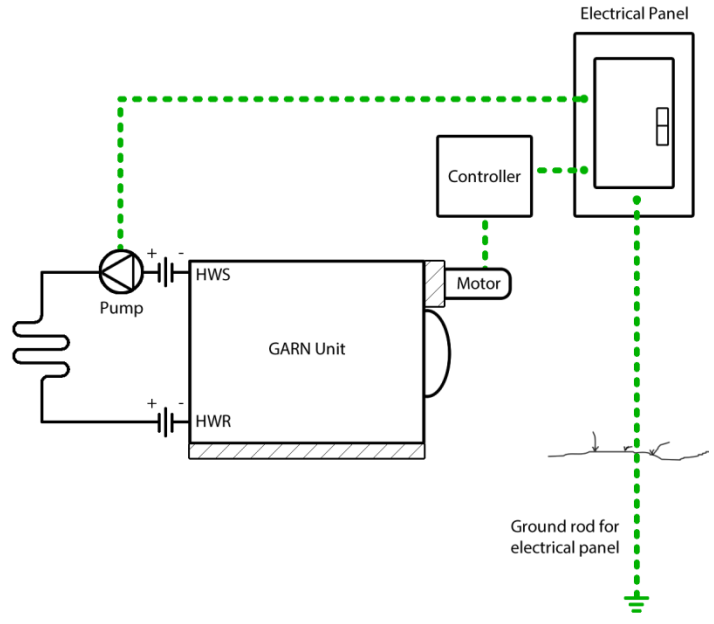

The GARN unit is now fully electrically isolated. Anode rods are not needed. If the installation changes over time and other electrical devices are installed on or near the GARN unit that are wired to ground, keep these concepts in mind and isolate appropriately.



**UNITS WITHOUT ELECTRIC HEATING ELEMENTS:**

**SINGLE POINT GROUNDING (OPTION 2):**

**1** Disconnect the independent ground rod:

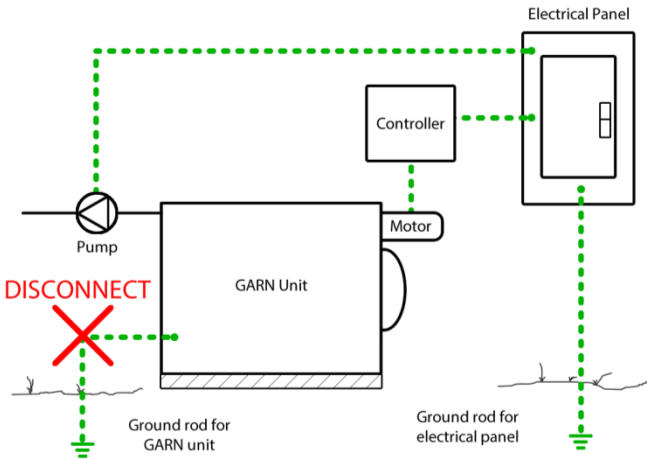

**2** Check to ensure that the unit is set on foam:

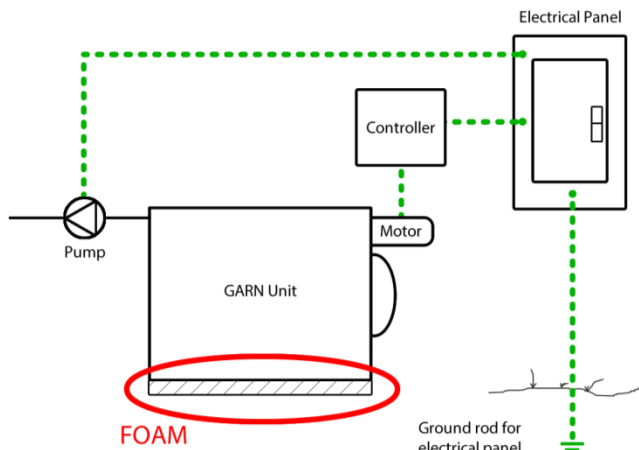

**3** Check to ensure that the blower motor and **ANY** pump that **IS NOT** dielectrically isolated from the GARN unit is wired to the same electrical panel:

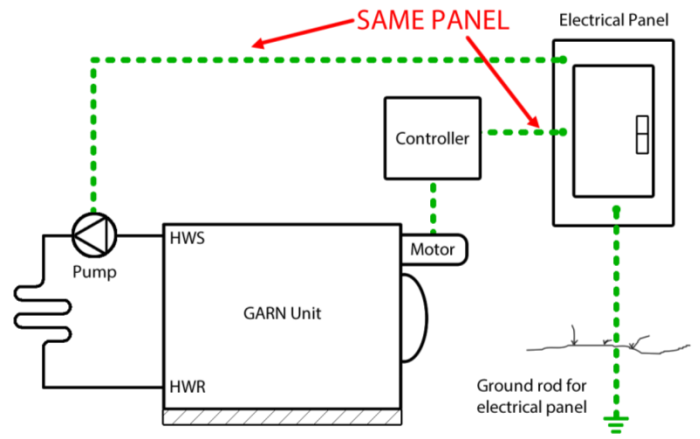

**4** If a pump connected directly to the GARN unit is wired to a different panel, then the pump **OR** blower motor **or both** must be electrically isolated:

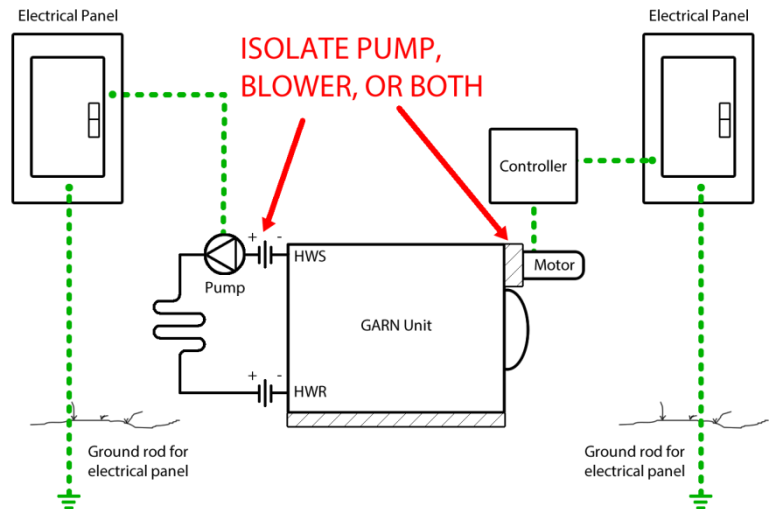

Isolate the blower motor with a blower motor isolation kit: (Part #: [P-0125 on www.garnparts.com](http://www.garnparts.com)). Installation instructions for the isolation kit can be found on [PAGE 8](#).

A pump is dielectrically isolated if there is a means that breaks the metal-to-metal contact between the pump housing itself and the GARN unit. Examples of di-electric isolation include: dielectric unions, any length of PEX, or isolation valve flanges attached directly to the pump (such as [Grundfos dielectric isolation valves](#)).

**5** Single point grounding is now complete. All ground pathways in contact with the GARN unit should now be wired to the same panel, and, ultimately, the same ground.



**UNITS WITH ELECTRIC HEATING ELEMENTS:**

Units with electric elements CANNOT be fully electrically isolated (per the National Electric Code). The solution is then to ground to a single point. But the single point ground must run through the panel providing power for the electric elements.

The following diagram shows a typical GARN installation with electric heating elements, no electrical isolation and potentially three separate ground paths: one through the electrical panel feeding the pump and controller, one through the independent ground rod of the GARN unit, and one through the electric element sequencer.

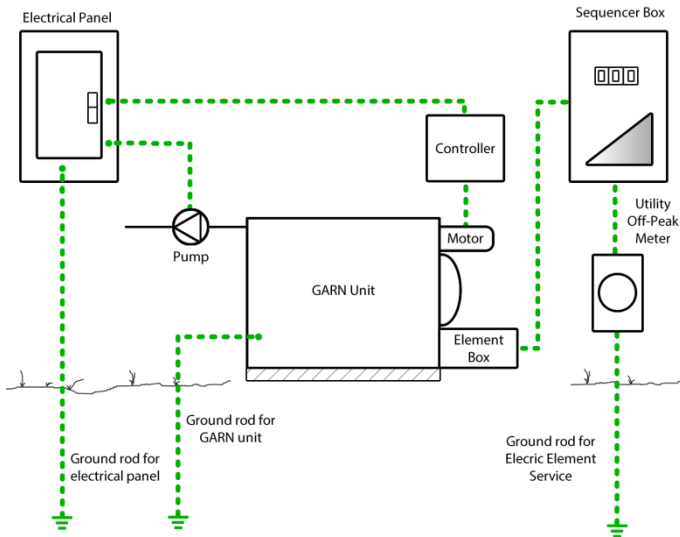

The goal is to build to a single-ground point through the element box, the sequencer box, and ultimately the ground rod associated with the electric heating element service. To do this:

- 1 Follow the steps in the [FULL ISOLATION \(OPTION 1\)](#) section on [PAGE 3](#)

- 2 After completing the full isolation steps, the installation should now look like the following figure. The only ground connection should be through the sequencer box.

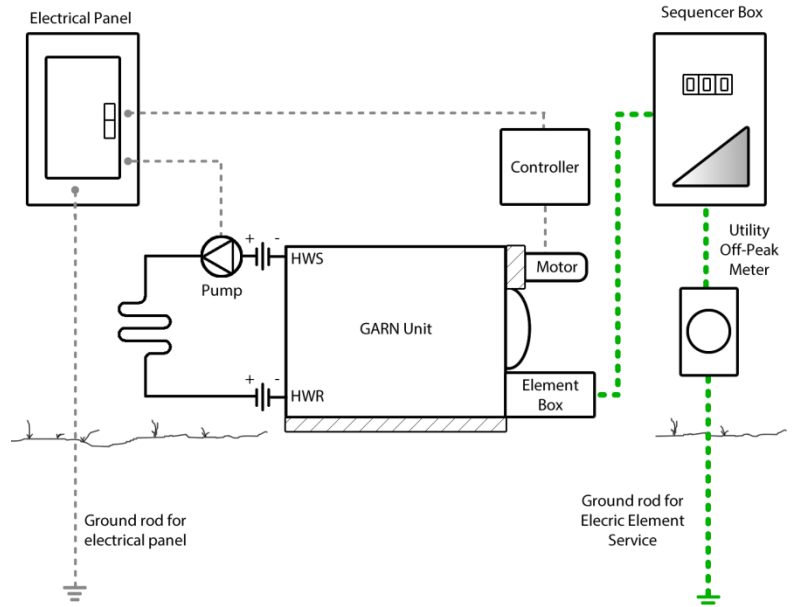

- 3 Ensure that the unit is grounded through the element box by attaching the ground wire to one of the studs in the electric element box. The ground wire must ultimately run back to ground of the meter/panel supplying power to the electric elements.

**ATTACH THE GROUND WIRE TO THE ELECTRIC ELEMENT BOX MOUNTING STUD**

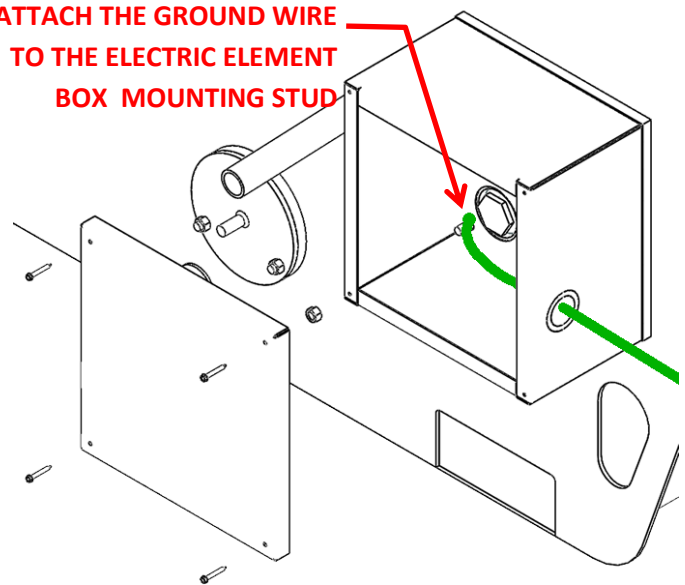

- 4 Single-point grounding with electric heating elements is now complete.



**CONCLUSION:**

Up to this point, anode rods were supplied with GARN units because they were a simple solution to deal with the possibility of undirected current or stray current. Anodes were installed in 100% of units to prevent an issue that might occur in less than 1% of units. But now that customers have experienced sloughing and accelerated rod degradation, the use of anode rods no longer meets our standards of broad protection (i.e., as a low-cost, low-maintenance solution for protection against undirected current).

Electric isolation is an equivalent substitute for the installation of consumable anode rods and accomplishes the same level of protection. Electric isolation will now be the standard installation method for all GARN units to combat complications from undirected current. Customers should evaluate their anode rods and then take appropriate action as outlined in this document and the previous service bulletins.

**FAQ:**

Some questions may arise after reading this document. We decided to put a FAQ section on our technical service bulletin webpage at: <http://www.garn.com/technical-service-bulletins/>

The goal is to answer customer questions that may not fit into the exact context and structure of this document. As customers ask questions, we will post answers to the webpage. If you have a question, please submit it to [support@garn.com](mailto:support@garn.com)



**ELECTRIC ISOLATION BUSHING INSTALLATION INSTRUCTIONS:**

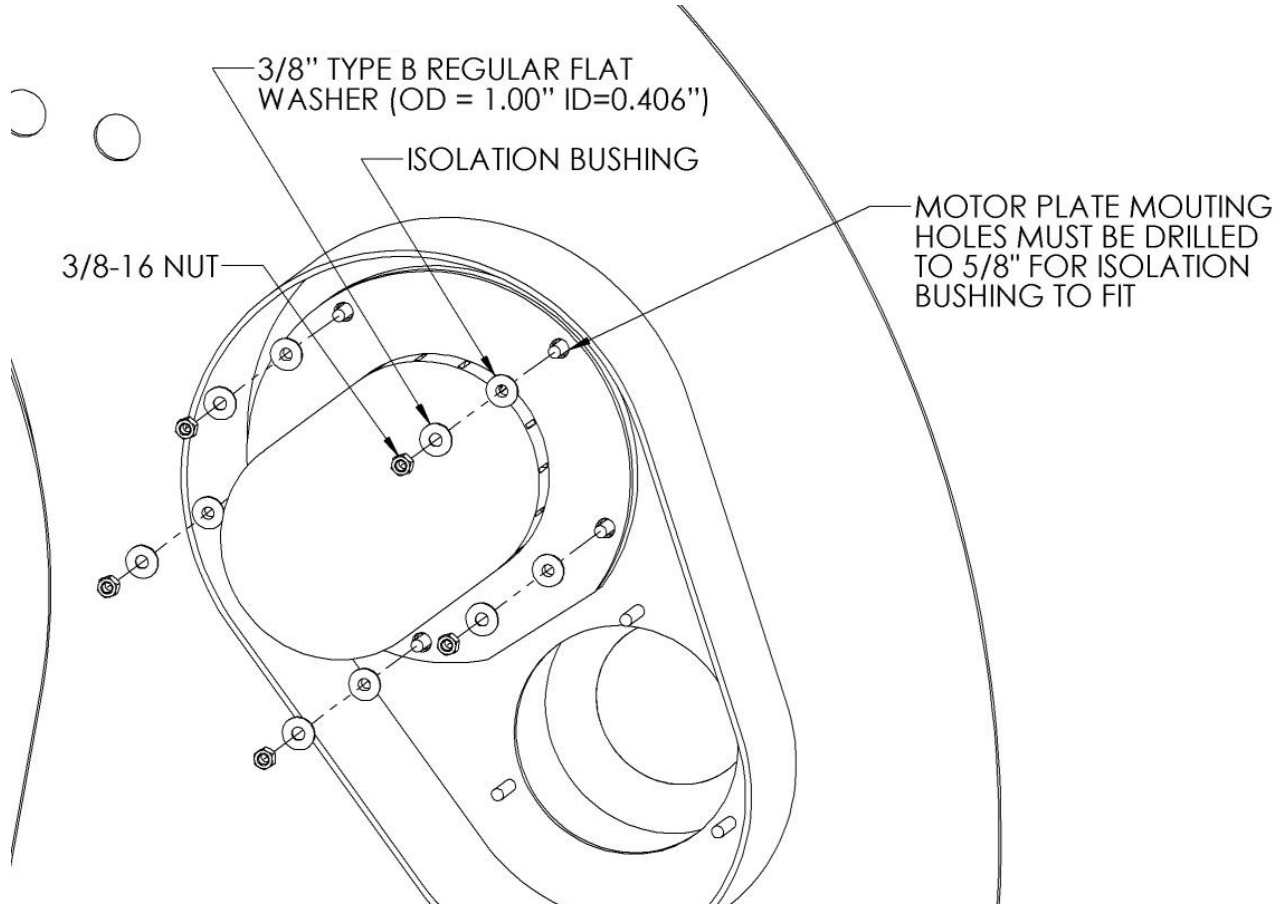

**PURPOSE OF THE ISOLATION BUSHING:**

The isolation bushings are designed to prevent undirected current from reaching the storage tank.

The blower motor's housing is electrically grounded through the motor power cord, and the motor's housing is also directly connected to the steel tank through the mounting studs. Electric current has the potential to find its way from the building's electrical panel through the motor housing and into the tank. As a result, undirected current is possible. Undirected current can increase the effect of galvanic corrosion or directly cause corrosion. Using the isolation bushings will eliminate the motor as a undirected current source and may help to extend the life of the steel tank. The isolation bushings are made from an electrically none-conductive, high-temperature Nylon plastic.

**INSTALLATION:**

Install the isolation bushings as shown above:

1. Remove the motor and blower assembly.
2. Drill out all of the motor plate mounting holes with a 5/8" drill bit.
3. Test fit all of the isolation bushing into the newly drilled holes. Ensure that they all fit. They will be loose, which is fine. The loose fit helps compensate for any dimensional tolerance in the stud spacing.
4. Test fit the plate with the bushings onto the studs (if the plate was removed in Step 1 or 2). If the assembly is hard to fit on the studs, evaluate and drill any problem holes out with the next larger drill bit.
5. Reinstall the motor assembly onto the studs.
6. Install the flat washers and nuts.